



Research Paper

Children's task persistence in first grade: The role of parent-child and teacher-child relationships

Justina Davolyte^{a,*}, Noona Kiuru^a, Saule Raiziene^b, Gintautas Silinskas^a

^a Department of Psychology, University of Jyväskylä, Finland

^b Institute of Psychology, Vilnius University, Lithuania

ARTICLE INFO

Keywords:

Parent-child relationship
Teacher-child relationship
Task persistence
First grade

ABSTRACT

The present study investigated the extent to which the quality of both parent-child and teacher-child relationships uniquely and interactively relates to a child's task persistence in first grade. Furthermore, the study also examined the role of a child's task persistence in the quality of their relationships with their parents and teachers after controlling for the child's gender, temperament, academic performance, and parental education level. The study followed Lithuanian children from the beginning (T1, $n = 337$) to the end (T2, $n = 341$) of first grade, along with their parents (T1, $n = 347$; T2, $n = 323$) and first-grade teachers (T1, $n = 24$; T2, $n = 25$). At the start of first grade, the children completed reading, spelling, and math (i.e., addition and subtraction) performance tests. The parents and teachers filled out questionnaires at the beginning and end of these students' first-grade academic year. The parents reported on the quality of their relationships with their children and on their children's temperament, while teachers reported on their relationship quality with each student and their task persistence. First, the results indicated that a conflictual relationship between the students and their teachers was related negatively to subsequent task persistence. Second, the moderation results indicated that if the teacher-child relationship was close, then a close parent-child relationship longitudinally was related positively to the children's task persistence. Third, the results indicated that a child's higher level of task persistence was associated longitudinally with a closer relationship with their first-grade teachers.

1. Introduction

Many children enter first grade highly motivated to learn. Simultaneously, they are exposed to new academic tasks that can be challenging (Torgrimson et al., 2021). Furthermore, different levels of academic skills can be related to a lack of persistence among some children in the face of such challenging tasks (Kikas et al., 2016; Merritt et al., 2012). As children's learning takes place in social circumstances, established relationships with significant adults (parents and teachers) can serve as a motivational resource and social support system for children to overcome challenges related to academic tasks (Pianta, 1997; Skinner, 2016; Verschueren & Koomen, 2012).

Empirical evidence indicates that parent- and teacher-child relationship quality can be associated with children's academic outcomes (Pianta, 1997; Pianta & Stuhlman, 2004). However, we know less about how parent- and teacher-child relationship quality and children's motivational behavior, including task persistence, are interrelated mutually. In particular, to the best of our knowledge, the cumulative and

compensatory effects of parent- and teacher-child relationship quality on children's task persistence in first grade have not been examined previously. Only a few extant studies have examined the interaction effects of parent and teacher relationship quality on children's academic outcomes at the very beginning of primary school (Heatly & Votruba-Drzal, 2017; Kiuru et al., 2016). Furthermore, how children approach tasks also can be related longitudinally to parents and teachers' subsequent affective responses and, thus, to the quality of parent- and teacher-child relationships (Sameroff & Mackenzie, 2003; Silinskas et al., 2015; Wentzel, 2016). However, the question of whether a child's task persistence after the critical transition to primary school is linked longitudinally to their relationships with their parents and teachers has not yet been examined.

Consequently, the present study aimed to shed further light on the reciprocal associations and possible interaction effects of parent-child and teacher-child relationships on first-grade children's task persistence among a sample of Lithuanian children.

* Corresponding author at: Department of Psychology, University of Jyväskylä, P.O. Box 35, 40014 Jyväskylä, Finland.
E-mail address: justina.davolyte@jyu.fi (J. Davolyte).

<https://doi.org/10.1016/j.ecresq.2024.04.010>

Received 30 January 2023; Received in revised form 19 October 2023; Accepted 30 April 2024

Available online 4 May 2024

0885-2006/© 2024 The Authors. Published by Elsevier Inc. This is an open access article under the CC BY license (<http://creativecommons.org/licenses/by/4.0/>).

1.1. Children's task persistence and parent- and teacher-child relationship quality

During a regular school day, children must complete different reading, writing, and math tasks that their classroom teacher assigns. Thus, children's motivational behavior—i.e., *task persistence*—can be defined as children's attention focus and active behavioral effort to stay on task, even if the task becomes difficult (Onatsu-Arvilommi & Nurmi, 2000; Zhang et al., 2011). Such behavior can become a critical component of successful learning. Previous studies have indicated that children who make active efforts to complete difficult academic tasks more often have rewarding learning experiences. Therefore, they are more likely to have a positive attitude toward themselves and the school, perform better, and acquire higher-level literacy and math skills (Grimm et al., 2010; Heatly & Votruba-Drzal, 2019; Hughes et al., 2008; Kikas & Silinskas, 2016; Onatsu-Arvilommi & Nurmi, 2000). However, some children may struggle to remain persistent when faced with difficult tasks. Various individual and contextual factors might be related to such challenges.

Parent-child and teacher-child relationship quality represents an important contextual factor that might be related to children's task persistence (Davis, 2003; Driscoll et al., 2011; Pianta et al., 1997; Skinner, 2016; Wentzel, 2016). According to attachment theory (Ainsworth, 1989; Bowlby, 1982) and self-determination theory (SDT) (Reeve, 2002; Ryan & Deci, 2000), positive parent- and teacher-child relationships represent a supportive learning environment in which parents and teachers constructively help children direct and coordinate their learning-related behaviors toward tasks (Pianta, 1997). However, negative parent-child and teacher-child relationships might be related to difficulties in providing constructive guidance and might be associated with how children approach difficult tasks (Pianta, 1997).

In light of these findings, and based on the attachment relationship model (Pianta, 2001; Verschuere, 2015), in the present study, we focused on two distinct, but related, relationship qualities: closeness and conflict (Pianta, 1997; Roorda et al., 2017; Spilt & Koomen, 2009). Closeness represents a positive relationship in which the interaction between a child and their parents or teachers is sensitive, warm, and accompanied by open communication and positive emotions (Kiuru et al., 2020; Pianta, 1992; Pianta et al., 2001). In contrast, conflict represents a negative relationship in which these same interactions are hostile, withdrawn, and imbued with negative emotions and difficulties in regulating the child's behavior in positive ways (Kiuru et al., 2020; Pianta, 1992; Pianta, 2001). Theoretically, we expected that more positive relationships with adults at home and in school would be found to provide children with a sense of safety and belonging and, thus, relate to children's task persistence (Davis, 2003; Furrer & Skinner, 2003; Kikas & Tang, 2019; Pianta, 1997; Reeve, 2002).

Children's own characteristics may play a key role in their relationships with significant others (parents and teachers), which can unfold in several ways. On one hand, according to attachment theory (Ainsworth, 1989; Bowlby, 1982; Davis, 2003), children's relationships with their teachers are perceived as an extension of their early relationships with their parents because children bring their own beliefs and mental models about what a relationship with adults should look like to the classroom (Davis, 2003). On the other hand, children's individual characteristics and behaviors in academic situations can be associated with certain responses from significant adults (Davis, 2003; Heatly & Votruba-Drzal, 2017; Silinskas et al., 2015; Wentzel, 2016). This, in turn, can be related to the quality of parent- and teacher-child relationships. Thus, children's task persistence and their formation of relationships during first grade can be a somewhat complex process. This warrants investigating bidirectional longitudinal associations between parent-child and teacher-child relationships and children's task persistence.

1.2. Interaction between parent- and teacher-child relationship quality

According to Bronfenbrenner's ecological systems theory (1986), a child's development process is shaped by the interaction between different contextual circumstances and the child's individual characteristics. How this process unfolds in any one context is not an isolated instance, as it continuously associates with other developmental contexts (Bronfenbrenner, 1986). Considering that relationships with teachers come into a child's life later than those with parents, they are built on these earlier relationships with parents. Newly established relationships with teachers that emerge alongside old ones with parents can be related to a child's academic outcomes in two ways (Acar et al., 2018; Silinskas & Kikas, 2022). First, the quality of a child's relationships with their parents and teachers may be related cumulatively to the child's academic outcomes (Acar et al., 2018; Murray, 2009), i.e., close relationships with both parents and teachers may be related to higher task persistence. Alternatively, conflictual relationships in both contexts may be negatively related cumulatively to lower task persistence in children. Second, high-quality relationships in one context may have a compensatory function vis-à-vis low-quality relationships in another (Buyse et al., 2011; Davis, 2003; Heatly & Votruba-Drzal, 2017; Kiuru et al., 2016). Thus, close relationships in one context (with parents at home) may protect children from academic difficulties related to conflictual relationships in another context (conflictual relationships with teachers). Similar compensatory interrelations can be expected concerning conflictual relationships with parents and teachers.

Empirical evidence also has indicated that the home and school contexts are interrelated and together may relate to a child's learning outcomes across different education stages (for preschool, see Acar et al., 2018; for kindergarten, see Buyse et al., 2011; for primary school, see Heatly & Votruba-Drzal, 2019; and for secondary school, see Murray, 2009). However, investigations into how interactions within parent- and teacher-child relationships have been related to children's motivational behavior (task persistence) immediately after the critical transition to first grade thus far have been rare. For example, some studies on first-grade students have focused on more general aspects of children's academic functioning, e.g., classroom engagement (Heatly & Votruba-Drzal, 2017) or adjustment to school (Kiuru et al., 2016). Furthermore, other studies have elicited mixed results about possible cumulative and compensatory interaction effects of parent- and teacher-child relationships on a child's academic functioning. For example, Heatly and Votruba-Drzal (2017) found that a high-quality relationship with the mother (greater closeness or sensitivity) can function as a buffer against low classroom engagement for children experiencing high-conflict relationships with their first-grade teacher (suggesting a compensatory interaction). Similarly, Kiuru et al. (2016) found that a supportive relationship with either the mother or a teacher can protect children from adjustment problems after entering school when one context is not supportive (also indicative of a compensatory interaction). However, in the latter study, the authors analyzed different aspects of supportive relationships (e.g., maternal support and positive teacher affect) and reported that low support from mothers and teachers (i.e., low maternal support and low positive teacher affect) had a greater negative relation with second-grade students' adjustment at school in terms of externalizing behavioral problems and prosocial behaviors (suggesting a cumulative interaction). However, Heatly and Votruba-Drzal's (2017) results did not indicate any cumulative effect of parent- and teacher-child relationships on children's classroom engagement. Thus, while previous research has indicated that the quality of a child's relationship with their parents and teachers may be related to their academic outcomes from the moment they begin primary school, more research is needed concerning which interaction type—cumulative or compensatory—is related empirically to children's task persistence in first grade.

Longitudinal associations between children’s task persistence and the quality of relationships with parents and teachers

It has been argued that the links between a child’s developmental context and their individual characteristics are bidirectional (Sameroff & Mackenzie, 2003). This assumption arises from the transactional model (Sameroff & Mackenzie, 2003). Thus, one can expect that favorable behavior among children is also likely to be related to positive responses from parents and teachers in terms of closer relationships, whereas unfavorable behavior can be related to negative responses in terms of conflictual relationships (Heatly & Votruba-Drzal, 2017; Nurmi, 2012).

Previous research has indicated that parents and teachers respond differently to children, depending on their individual characteristics (Jaruseviciute et al., 2022; Nurmi, 2012; Silinskas et al., 2015). For example, studies have indicated that a child’s task persistence in primary school is related to higher parental support in learning situations (Kikas & Silinskas, 2016; Viljaranta et al., 2018). Similarly, Nurmi’s (2012) meta-analysis of a child’s individual characteristics on the teacher-child relationship indicated that teachers are more likely to establish closer relationships with students who demonstrate high levels of motivation and engagement in learning. Thus, previous studies have provided evidence that a child’s motivational behavior might be associated longitudinally with parent- and teacher-child relationships. However, these studies only considered one interpersonal environment at a time (i.e., parents or teachers). Thus, little is known whether first graders’ task persistence longitudinally relates to their relationship quality with parents and teachers. Addressing this issue is important because children spend a reasonable amount of time at school. Furthermore, this new developmental stage (entrance to first grade) also might elicit changes in relationships with parents.

Lithuania’s education system

The present study was conducted in Lithuania, a country in north-eastern Europe. Thus, some cultural features (e.g., the education system’s specificity) also can be relevant in interpreting the present study’s results. Compulsory education in Lithuania starts one year before first grade, i.e., all children must attend kindergarten one year before their primary schooling officially begins (LR Ministry of Education and Science, 2022). Kindergarten’s main goal is to promote comprehensive personality development and preparation to learn among children based on the primary education curriculum (LR Ministry of Education and Science, 2014). Usually, children enter primary school (first grade) at age seven. Primary school lasts four years, with classes assigned one teacher for all subjects (excluding physical, ethical, musical, and dance

education). Primary school classes usually begin at 8 a.m. and last until lunch (1 p.m.), with each class lasting 45 min. In first grade, children have four to five classes a day in the morning. After lunch, the children can attend a session in the afternoon in which another teacher organizes activities on the school’s premises. The school year starts on September 1, when first-graders usually meet their primary school teachers for the first time and finish before the middle of June. Usually, schools in urban areas have higher numbers of students in classrooms than those in rural areas. Some rural areas have children of various ages in the classroom (e.g., mixed classes for first and second grades or second through fourth grades), but this was not the case in our study.

Research questions

The present study aimed to investigate longitudinal bidirectional associations between parent- and teacher-child relationship quality and children’s task persistence during first grade and to test for possible interactions among these relationships. The following research questions (RQs) were examined (see Fig. 1):

1. To what extent is the quality of parent- and teacher-child relationships related to children’s subsequent task persistence at the end of first grade? We expected that close parent- and teacher-child relationships would be related positively to children’s task persistence at the end of first grade (Hypothesis 1a), whereas a conflictual relationship would be related negatively to children’s task persistence (Hypothesis 1b) (Cadima et al., 2015; Edwards et al., 2010; Merritt et al., 2012; Wu et al., 2010).
2. To what extent does the interaction of parent- and teacher-child relationship quality (parent-child closeness × teacher-child closeness, parent-child conflict × teacher-child conflict) longitudinally relate to children’s task persistence at the end of first grade?
 - 2.1. Due to previous studies’ mixed results, we proposed two hypotheses for closeness. We expected that a close relationship with teachers would function as a buffer against low task persistence related to low parent-child closeness, and that closeness with parents would function as a buffer against low task persistence related to lack of closeness with the teacher (compensatory interaction; Hypothesis 2a) (Kiuru et al., 2016). Higher task persistence was expected for children who had a close relationship with both parents and teachers (cumulative effect; Hypothesis 2b; Bronfenbrenner, 1986; Heatly & Votruba-Drzal, 2017).
 - 2.2. Similar to closeness, we formulated two hypotheses for conflict. We expected that a high amount of conflict within teacher-child relationships would be related less negatively to children’s task

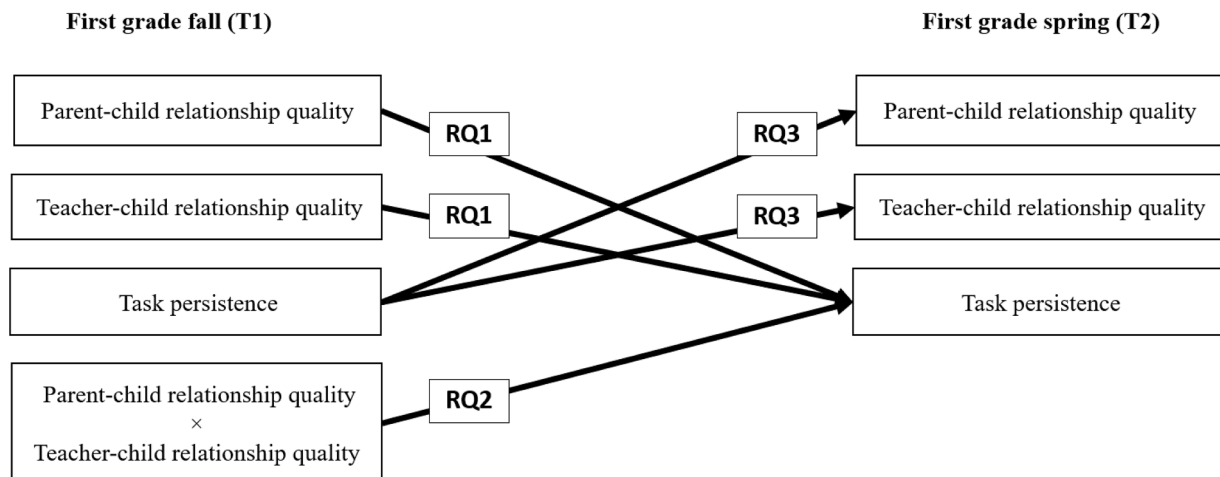

Fig. 1. Theoretical model for parent- and teacher-child relationship quality and children’s task persistence across first grade.

persistence when children experienced less-conflictual relationships with their parents. However, a high amount of conflict within the parent-child relationship would be related less negatively to children's task persistence when children experienced less-conflictual relationships with their teachers (compensatory interaction; Hypothesis 2c). Lower task persistence was expected for children who had a conflictual relationship with both parents and teachers (cumulative interaction, Hypothesis 2d; Acar et al., 2018; Bronfenbrenner, 1986; Kiuru et al., 2016; Murray, 2009).

3. To what extent is children's task persistence related to the subsequent quality of parent- and teacher-child relationships at the end of first grade? We expected that higher task persistence at the beginning of first grade would be related to higher parent- and teacher-child closeness at the end of first grade (Hypothesis 3a), as well as lower levels of parent- and teacher-child conflict (Hypothesis 3b) (Heatly & Votruba-Drzal, 2017, 2019; Nurmi & Kiuru, 2015; Silinskas et al., 2015).

In the present study, we controlled our results for the effects of three child characteristics (gender, temperament, and level of academic performance at the beginning of first grade) and one parental characteristic (highest parental education level). First, we chose to control for gender because typically, girls are more sensitive to relationship quality's effect (Furrer & Skinner, 2003; Koepke & Harkins, 2008), establish closer relationships with their parents and teachers (Wu et al., 2010), and demonstrate higher persistence (Kikas & Silinskas, 2016; Onatsu-Arviolommi & Nurmi, 2000). Second, previous studies have indicated that the child's temperament might be an important factor related to parent-child and teacher-child relationship quality (Jaruseviciute et al., 2022; Rudasill & Rimm-Kaufman, 2009). For example, the child's self-regulative temperament dimensions might be associated with more positive adults' perception of the child and, thus, also to a closer relationship between them (Rudasill & Rimm-Kaufman, 2009). Also, Jaruseviciute et al. (2022) found that low effortful control and high negative affectivity were associated with greater closeness and lower conflict with parents. As for teachers, children's higher negative affectivity was related to lower closeness (Jaruseviciute et al., 2022). Third, several authors have emphasized that academic performance relates to children's task persistence (Hughes et al., 2008; Kikas & Silinskas, 2016), suggesting that children who perform better academically usually approach difficult tasks with higher persistence. Finally, some studies have highlighted parental education level's importance on children's academic functioning, including task persistence (e.g., Kikas & Silinskas, 2016).

2. Methods

2.1. Participants and procedure

The present study is part of a larger longitudinal study (*study and authors removed*) that has followed children, their parents, and their teachers from the end of kindergarten to the end of first grade. The participants were recruited from six Lithuanian schools based on distribution of urban and rural localities (65 % urban and 35 % rural). Three schools from the urban area comprised 57.5 % of the sample, and three from the rural area comprised 42.5 %. Altogether, 71.96 % of all invited parents and 100 % of all teachers agreed to participate in the study. Initially, each school's administration was contacted and informed about the study's objectives and procedures. After the school administration agreed to participate, a meeting for teachers and school psychologists was organized with the purpose of introducing the study goals and procedures to them. Furthermore, training for school psychologists was organized twice on administration of the children's tests. Before starting data collection, the parents received an information letter about the study, including its goals and procedures, and had two

weeks to decide whether they and their children would participate. The parents also were told that their children could leave the study at any time. Even if parents gave consent for their children to participate in the study, they had a right not to provide answers to the parents' questionnaires. Only children whose parents gave their written consent to participate in the study were tested. A trained school psychologist administered the children's tests individually to each child. Before the testing session, the children were asked whether they agreed to participate in the school psychologist-administered tasks and were told that they could end their participation at any time.

Children's reading, writing, and math (i.e., addition and subtraction) skills were tested twice: at the beginning of first grade (T1, autumn; $n = 337$, 52.8 % girls; age: $M = 7.3$ years, $SD = 0.38$) and at the end of first grade (T2, spring; $n = 341$, 52.8 % girls). All participating children attended Lithuanian-speaking schools, with most of Lithuanian descent (94.9 %; 1.3 % Russian, 1.3 % Polish, 0.6 % Lithuanian and Russian, 1.3 % Lithuanian and Polish, and 0.6 % other/not specified). Although we did not ask the participants to report their ethnicity, they likely were almost entirely Caucasian—the dominant ethnicity in Lithuania. Most of the children had only one sibling (81.5 %), 15.3 % had two siblings, 3.2 % had three siblings, and 22 % had no siblings.

The parents were asked to fill out a questionnaire about their relationship with their children twice: during the autumn term of first grade (T1; $n = 347$) and during the spring term of first grade (T2; $n = 323$). They reported on their children's temperament at T1. The parents' mean age at T1 was 35.59 ($SD = 4.98$), ranging from 23 to 60 years. In the children's families, more than half the mothers (63 %) and fathers (52.5 %) had a university education, 18.8 % of mothers and 26.9 % of fathers had graduated from a college or polytechnic school, and 12.1 % of mothers and 15.3 % of fathers had only a secondary school degree. Independent sample *t*-tests indicated differences in parental education levels between urban and rural areas ($t[217.001] = -2.552$, $p = .006$; urban area: $n = 269$, $M = 4.81$, $SD = 0.72$; rural area $n = 134$, $M = 4.57$, $SD = 0.92$), indicating that urban parents had significantly higher levels of education than rural parents. Most of the children (79.6 %) lived in families with two co-resident parents (e.g., mother and father), and slightly more than a fifth of the children lived in other types of families (11.0 % with their mother only, 4.5 % with their mother and stepfather, and 4.9 % in other types, e.g., either with their father, father and stepmother, a guardian, or grandparents). Mothers filled out most of the questionnaires (T1: 91.1 %, T2: 88.7 %). The rest were filled out by fathers (T1: 5.5 %, T2: 7.9 %), both parents together (T1: 2.3 %, T2: 2.2 %), the father with another caregiver (T1: 0.3 %, T2: 0 %), or other (e.g., social worker, T1: 0.9 %, T2: 1.3 %).

The teachers were asked to fill out a questionnaire about each participating child in their classrooms (class size $M = 22.17$, $SD = 3.07$, ranging from 11 to 26) during the autumn first-grade term (T1; $n = 24$) and during the spring first-grade term (T2; $n = 25$). The teachers' mean age was 45.17 ($SD = 10.70$), ranging from 25 to 62 years. The average teaching experience in years was 21.69 ($SD = 12.22$), ranging from 0.25 to 41 years. All the teachers were female Lithuanian speakers with at least a bachelor's (70.8 %) or master's (29.2 %) degree in pedagogy. One class during the first measurement point (T1) was in quarantine due to the rapid spread of infectious diseases. Therefore, the teacher and children did not participate in the first measurement cycle and rejoined our study during the second cycle (T2).

2.2. Measures

All study variables' psychometric properties are presented in Table 1. All statistics, including internal consistency (Cronbach's alpha), were based on our present sample. All questionnaires and children's tests were administered in the Lithuanian language. Three independent translators (experts in developmental and educational psychology) translated the materials into Lithuanian. The best translation was chosen in a group meeting. For the final set of materials, a back-translation

Table 1
Descriptive statistics of the study variables, based on the current sample.

Variable	n	M	SD	Cronbach α	Range		Skewness
					Potential	Actual	
Task persistence (T1)	341	3.60	0.96	0.89	1–5	1–5	-0.58
Task persistence (T2)	335	3.55	0.97	0.91	1–5	1–5	-0.52
Parent-child closeness (T1)	341	4.28	0.45	0.71	1–5	2.88–5	-0.53
Parent-child conflict (T1)	341	2.45	0.73	0.80	1–5	1–5	0.60
Teacher-child closeness (T1)	342	3.97	0.54	0.73	1–5	2–5	-0.38
Teacher-child conflict (T1)	342	1.57	0.70	0.85	1–5	1–4.71	1.62
Parent-child closeness (T2)	321	4.22	0.47	0.74	1–5	2.75–5	-0.41
Parent-child conflict (T2)	319	2.51	0.75	0.91	1–5	1–5	0.55
Teacher-child closeness (T2)	334	3.84	0.60	0.80	1–5	1–5	-0.56
Teacher-child conflict (T2)	334	1.64	0.78	0.94	1–5	1–4.71	1.48
Covariates							
Child gender (0 girl, 1 boy)	409	0.46	0.50		0–1	0–1	0.15
Reading performance	337	16.56	11.60	0.96	0–75	0–59	0.92
Writing performance	337	28.64	9.65	0.91	0–40	0–40	-1.51
Addition performance	337	5.70	4.23	0.90	0–20	0–20	1.29
Subtraction performance	337	7.15	3.19	0.83	0–20	0–16	-0.07
Temperament							
Surgency	403	4.21	0.88	0.75	1–7	1.83–7	0.04
Negative affectivity	403	4.34	0.82	0.70	1–7	1.25–7	-0.04
Effortful control	403	5.36	0.75	0.75	1–7	2.5–7	-0.056
Highest level of parental education	400	4.61	0.72		1–5	1–5	-1.96

Note: T1 = first grade, fall term; T2 = first grade, spring term.

procedure was applied to ensure that test items’ meanings did not differ substantially from the originals. Before each measurement point in the main study, all the materials were piloted. Any inconsistencies (e.g., translation errors, typos, inappropriate questions for the Lithuanian cultural environment) were spotted and corrected.

2.3.1. Parent questionnaire

2.3.1.1. Parent-child relationship (T1 and T2). In the present study, we focused on positive and negative relationship quality. Therefore, to measure parent-child relationship quality, parents were asked to fill out the Child-Parent Relationship Scale (CPRS) short form (Pianta, 1992b). The parents answered 15 questions on a five-point Likert scale (1 = *Completely disagree*; 5 = *Completely agree*). The questionnaire measured two types of parent-child relationship quality: Closeness was measured using eight items (e.g., *I share an affectionate, warm relationship with the child*). Conflict was measured using seven items (e.g., *My child is uncomfortable with physical affection or touch from me*). The scale has been used widely in previous research and has demonstrated good internal consistency, with Cronbach’s alphas ranging from 0.69 to 0.86 (Acar et al., 2018; Kiuru et al., 2020; Driscoll et al., 2011). In the present study, internal consistency was good for both measurement points (see Table 1). Both subscales’ mean scores were counted separately, with higher scores representing greater parent-child closeness and higher parent-child conflict.

2.3.2. Teacher questionnaire

2.3.2.1. Teacher-child relationship (T1 and T2). We focused on positive and negative relationship quality, so to measure teacher-child relationship quality, teachers were asked to fill out the Student-Teacher Relationship Scale (STRS) short form (Pianta, 1992a, 2001). The teachers answered 15 questions on a five-point Likert scale (1 = *Completely disagree*; 5 = *Completely agree*) that measured two types of teacher-child relationship quality: Closeness was measured using eight items (e.g., *I share an affectionate, warm relationship with this child*). Conflict was measured using seven items (e.g., *This child is uncomfortable with physical affection or touch from me*). Previous studies reported good internal consistency in the scales, with Cronbach’s alphas ranging from 0.86 to 0.91 (Buyse et al., 2009; Hamre & Pianta, 2001; Maldonado-Carreño & Votruba-Drzal, 2011; Settanni et al., 2015). In the present

study, internal consistency was good at both measurement points (see Table 1). The scale’s validity has been tested. Associations with a variety of children’s learning outcomes have been demonstrated (Hamre & Pianta, 2001; Pianta, 2001; Settanni et al., 2015). For example, Settanni et al. (2015) study indicated adequate factor loadings of 0.48 to 0.71 for closeness and 0.58–0.72 for conflict. Both subscales’ mean scores were calculated separately, with higher scores representing greater teacher-child closeness and higher teacher-child conflict.

2.3.2.2. Task persistence (T1 and T2). Teachers provided information about children’s task persistence by rating five items (e.g., *Does the student have a tendency to find something else to do instead of focusing on the task at hand? Does the student give up easily? If the activity or task is not going well, does the student lose his/her focus?*) from the Behavioral Strategy Rating Scale (BSRS) (Aunola et al., 2000; Zhang et al., 2011) on a five-point Likert scale (1 = *Completely disagree*; 5 = *Completely agree*). We used teachers’ assessments of children’s task persistence regardless of their perceptions’ possible influence on the ratings because of their opportunity to observe how children persist with tasks throughout the day. Therefore, they assessed task persistence at a more general, instead of a situation-specific, level. The scale’s validity and reliability were tested using Zhang et al. (2011) four-point method, revealing good reliability coefficients (Cronbach’s alpha range: 0.83–.86) and satisfactory validity (factor loadings ranged from 0.47 to 0.93 across time points). In the present study, internal consistency was good at both measurement points (see Table 1). The mean score of all five questions was used as a composite score, with higher scores indicating higher task persistence in children.

2.3.3. Control variables

The four control variables used in this study were child’s gender, three temperament dimensions, parental education level, and child’s academic performance at the beginning of first grade. First, child gender was coded as 0 = girl and 1 = boy. Second, parents filled out a questionnaire on their children’s temperament, the Children’s Behavior Questionnaire-Very Short Form (Putnam & Rothbart, 2006; Rothbart et al., 2001). Altogether, parents rated 36 items on three temperament dimensions (surgency/extraversion, negative affectivity, and effortful control) on a scale from 1 to 7 (1 = *does not fit at all*, 7 = *fits me very well*). Third, parents provided information about their highest education levels. For future analyses, we created a new variable representing the

highest education level that either parent achieved by selecting the education of the parent with the higher level of the two (1 = finished 0–8 years, 2 = 9–10 years, 3 = 11–12 years, 4 = college or polytechnic, 5 = university). Fourth, the children’s academic performance was assessed using four different tests completed during the individual child testing sessions at the beginning of first grade (all tests’ Cronbach’s alphas are provided in Table 1 based on the current sample). The reading and spelling tests were based on Gedutienė (2008) and Lerkkanen et al., and Ketonen (2006) test batteries. To measure reading skills, children had to read 75 words out loud that their school psychologist administered. The score was the number of words read correctly in 45 s (0 = Incorrect; 1 = Correct). During the spelling test, the children had to write down 10 words that the school psychologist uttered. Every word was scored by counting correctly written letters (0 = Incorrect; 0.5 = One letter, but not the first, is correct; 1 = First letter of the word is correct; 2 = Two or more letters spelled correctly; 3 = Correct phonetic structure of the word but switched letters; 4 = Correctly spelled word). Math performance was assessed using two math tests, addition and subtraction, based on Aunola and Räsänen (2007). Each child received written addition tasks that they had to calculate, then report their answers to the school psychologist. The number of correct answers obtained within three minutes was counted (0 = Incorrect; 1 = Correct). After addition, the child received written subtraction tasks that they had to calculate, then report their answers to the investigator. The number of correct answers within three minutes was counted (0 = Incorrect; 1 = Correct). At T1, children were given 20 addition and 20 subtraction tasks. At T2, the children were given 23 addition tasks and 23 subtraction tasks. The decision to increase the number of items was made to reduce the possibility of a ceiling effect at T2. To create a child performance score, the reading, spelling, addition, and subtraction test scores were standardized (z-score), then the four standardized variables’ mean score was computed.

2.4. Data analysis strategy

The data were analyzed using Mplus, Version 8.8 (Muthén & Muthén, 2017). All available cases were included in the present study. The missing data across the variables (task persistence, parent-child relationship quality, teacher-child relationship quality, academic performance, highest parental education level, and temperament dimensions) ranged from 1.5 % for temperament dimensions to 21 % for parent-child conflict at T2 (M = 16.66 %, SD = 3.95) and were not missing completely at random (Little’s MCAR test: $\chi^2 = 321.444$, $df = 263$, $p = .008$). To address the problem of missing values, we used the full information maximum likelihood (FIML) procedure. Some data were skewed; thus, we used the maximum likelihood robust estimator (MLR). Considering that the teachers provided responses about more than one child in the classroom, in all analyses, Mplus’ COMPLEX function was utilized, with the first-grade classroom ID as the clustering variable. Five criteria were used to investigate whether the model fit the data, which included the chi-square test of model fit (χ^2), root-mean-square error of approximation (RMSEA), comparative fit index (CFI), Tucker-Lewis index (TLI), and standardized root-mean-square residual (SRMR). To obtain a good model fit, we expected the p value for χ^2 to be higher than 0.05, the RMSEA to be smaller than 0.06, the CFI and TLI to be higher than 0.95, and the SRMR to be lower than 0.08 (Hu & Bentler, 1999).

Before the main analysis, we conducted a descriptive analysis. First, we estimated the correlation coefficients between all study variables. Second, we compared the differences between the children’s task persistence, parent-child relationship quality (closeness and conflict), and teacher-child relationship quality (closeness and conflict) at the beginning (T1) and end (T2) of first grade. Third, we compared the differences between girls and boys on all main study variables.

To answer the RQs about the interrelations between parent- and teacher-child relationship quality and children’s task persistence, two separate cross-lagged panel models were built: one for relationship

closeness and task persistence, and another for relationship conflict and task persistence. To build these path models, parent- and teacher-child relationship quality (T1) were specified to predict children’s task persistence at the end of first grade (T2; RQ1). Children’s task persistence (T1) was added to predict parent- and teacher-child relationship quality (T2; RQ3). Cross-lagged paths between parent-child and teacher-child relationship quality across T1 and T2 were estimated. Child academic performance at the beginning of first grade, gender, temperament dimensions, and parents’ highest education level were controlled for by estimating all T2 variables’ direct paths. Correlation coefficients were estimated between parent- and teacher-child relationship quality, the child’s task persistence, and the control variables at the beginning of first grade (T1). Furthermore, concurrent correlations between the residuals of parent- and teacher-child relationship quality and child task persistence were specified at the end of first grade (T2). To answer RQ2, we tested two interaction effects at T1 (parent-child closeness × teacher-child closeness, parent-child conflict × teacher-child conflict) with respect to children’s task persistence at T2, controlling for previous level of task persistence and control variables.

3. Results

3.1. Descriptive statistics

Means and standard deviations for all the study variables are presented in Table 1. Descriptive statistics by gender are presented in Table 2. The results from the zero-order correlations are presented in Table 3 and interpreted following Cohen’s (1988) recommendations. The results indicated that children’s task persistence at both measurement points was positively correlated moderately with teacher-child closeness, negatively correlated strongly with teacher-child conflict, negatively correlated weakly with parent-child conflict, and not significantly correlated with parent-child closeness. Furthermore, children’s task persistence at T1 was positively correlated strongly with task persistence at T2. Furthermore, parent-child closeness and conflict, as well as teacher-child closeness and conflict, were negatively correlated moderately.

The paired sample t-test did not indicate any significant changes between children’s task persistence at the beginning of first grade (T1) and at the end (T2) ($t[333] = 1.922$, $p = .055$). However, some significant changes appeared in parent-child relationship quality, as parent-child closeness significantly decreased ($t[311] = 2.511$, $p = 0.013$), and parent-child conflict significantly increased ($t[309] = -2.010$, $p = .045$). Similarly, significant changes were observed in teacher-child

Table 2
Descriptive statistics for gender differences in children’s task persistence and closeness and conflict ratings by parents and teachers at the beginning and end of first grade.

	T1		T2	
	M	SD	M	SD
Task persistence				
Girls	3.79	0.90	3.74	0.89
Boys	3.42	0.96	3.32	1.01
Parent-child closeness				
Girls	4.32	0.46	4.24	0.48
Boys	4.23	0.43	4.20	0.47
Parent-child conflict				
Girls	2.44	0.70	2.54	0.76
Boys	2.43	0.71	2.46	0.72
Teacher-child closeness				
Girls	4.10	0.51	3.98	0.55
Boys	3.84	0.54	3.68	0.61
Teacher-child conflict				
Girls	1.43	0.61	1.47	0.6
Boys	1.73	0.74	1.83	0.91

Note: T1 = first grade, fall term; T2 = first grade, spring term.

Table 3
Correlations Between the Study Variables.

Variable	1	2	3	4	5	6	7	8	9	10	11	12	13	14	15
1 Task persistence (T1)	1														
2 Task persistence (T2)	.745**	1													
3 Parent-child closeness (T1)	.06	.053	1												
4 Parent-child conflict (T1)	-0.148**	-0.177**	-0.385**	1											
5 Teacher-child closeness (T1)	.390**	.336**	.104	-0.005	1										
6 Teacher-child conflict (T1)	-0.528**	-0.550**	-0.155**	.133*	-0.420**	1									
7 Parent-child closeness (T2)	-0.024	.089	.634**	-0.320**	.064	-0.093	1								
8 Parent-child conflict (T2)	-0.129*	-0.138*	-0.342**	.747**	-0.028	.133*	-0.385**	1							
9 Teacher-child closeness (T2)	.397**	.530**	.112*	-0.126*	.553	-0.403**	.172**	-0.096	1						
10 Teacher-child conflict (T2)	-0.363*	-0.576**	-0.101	.132*	-0.195**	.727**	-0.129*	.113*	-0.476**	1					
11 Child gender (0 girl, 1 boy)	-0.215**	-0.215**	-0.101	.003	-0.231**	.231**	-0.036	-0.05	-0.258**	.234**	1				
12 Academic performance	.499**	.442*	-0.041	-0.051	.198**	-0.155**	-0.067	.085	-0.093	-0.093	-0.014	1			
13 Temperament surgency	-0.142**	-0.172**	-0.006	.041	.006	.130*	-0.018	.006	.107	.107	.117*	-0.041	1		
14 Temperament negative affectivity	-0.055	-0.074	-0.073	.392**	.137*	-0.136*	-0.074	.295**	-0.128*	.045	-0.017	-0.084	-0.140**	1	
15 Temperament effortful control	.078	.109*	.349**	-0.164**	.078	-0.072	.332**	-0.232**	.169**	-0.102	-0.235**	-0.089	-0.212**	.048	1
16 Highest level of parental education	.280**	.305**	.031	-0.085	.220**	-0.175**	-0.058	-0.085	.120*	-0.119*	-0.081	.347**	-0.044	-0.147**	-0.042

Note: T1 = first grade, fall term; T2 = first grade, spring term.

* $p < 0.05$;

** $p < 0.01$.

relationship quality, in that teacher-child closeness decreased ($t[333] = 4.636, p < 0.001$). and teacher-child conflict increased ($t[315] = -17.271, p < 0.001$).

The independent sample t -test revealed some significant gender differences. First, there was a significant difference was found between girls' and boys' task persistence at the beginning of first grade ($t [323.254] = 4.023, p < 0.001$) and at the end of first grade ($t[334] = 4.029, p = < 0.001$), in that task persistence was lower among boys than girls. Second, the results indicated no differences between girls' and boys' relationship closeness with parents (T1: $t[335.475] = 1.870, p = .062$; T2: $t[315.238] = 0.665, p = .513$) and conflict with parents (T1: $t [313.221] = 0.892, p = .373$; T2: $t[313.221] = 0.892, p = .186$). Third, the results regarding girls' and boys' relationship quality with teachers revealed significant gender differences in closeness (T1: $t[328.193] = 4.363, p < 0.001$; T2: $t[314.468] = 4.830, p < 0.001$) and conflict (T1: $t [340] = -4.384, p < 0.001$; T2: $t[333] = -4.393, p < 0.001$), suggesting that at both measurement points, girls had a closer and less-conflictual relationship with teachers than boys.

3.2. Path models

Previous studies analyzing relationship quality in terms of closeness and conflict have distinguished between the two, as negative relationships (conflict) are associated more strongly with children's learning outcomes (in terms of engagement and achievement; [Roorda et al., 2017](#)). Furthermore, some studies have provided evidence that closeness and conflict represent two distinct, but related, relationship domains ([Driscoll et al., 2011](#)). Therefore, to answer the RQs, two separate cross-lagged panel models were built for closeness and conflict.

3.2.1. Closeness model

The model for parent- and teacher-child closeness and task persistence is presented in [Fig. 2](#). The model fit the data well ($\chi^2 [7] = 14.094, p = .049, CFI = 1.000, TLI = 1.000, RMSEA = 0.000, SRMR = 0.000$). First, the results indicated stability in all the study constructs (0.439–0.646). Second, the results revealed that neither parent-child closeness nor teacher-child closeness at the beginning of first grade (T1) significantly predicted children's task persistence at the end of first grade (T2), thereby rejecting Hypothesis 1a. Third, children's task persistence positively predicted teacher-child closeness, in that the more persistent the child was at the beginning of first grade, the closer their relationship with their teacher was reported to be at the end of first grade, thereby supporting Hypothesis 3a. Notably, all these results were obtained after controlling for autoregressive effects and control variables.

Taken together, the findings concerning bidirectional associations between parent- and teacher-child closeness and children's task persistence revealed that a child's closeness with their parents and teacher was not a significant task persistence predictor. However, the child's task persistence at the beginning of first grade was a significant predictor of a close teacher-child relationship at the end of first grade.

3.2.2. Conflict model

The model for parent- and teacher-child conflict and task persistence is presented in [Fig. 3](#). The model fit the data well ($\chi^2 [6] = 12.247, p = .057, CFI = 0.989, TLI = 0.947, RMSEA = 0.054, SRMR = 0.013$). First, the results indicated stability in all the study constructs (0.524–0.752). Second, the results revealed that teacher-child conflict at the beginning of first grade (T1) negatively predicted children's task persistence at the end of first grade (T2), while parent-child conflict did not predict task persistence significantly, thereby partially supporting Hypothesis 1b. The more conflictual the relationship between the child and the teacher at the beginning of first grade (T1), the less persistent the child's behavior, as the teacher reported at the end of first grade (T2), after controlling for prior task persistence level and control variables. Furthermore, child task persistence did not predict parent- and teacher-

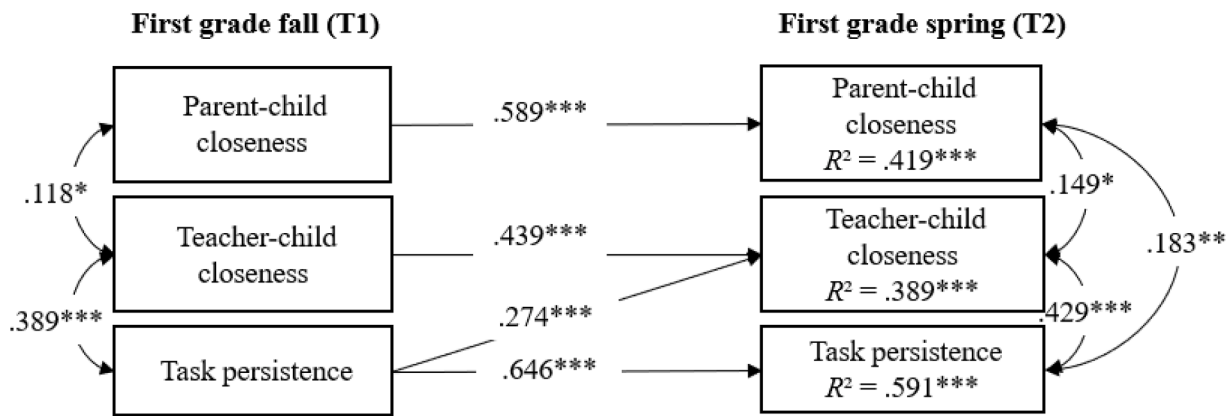

Fig. 2. Associations between parent- and teacher-child closeness and children's task persistence across first grade. Note: Covariates at T1 were allowed to correlate with parent- and teacher-child closeness and task persistence at T1. Covariates at T1 were specified to predict parent- and teacher-child closeness and task persistence at T2. * $p < 0.05$, ** $p < 0.01$, *** $p < 0.001$.

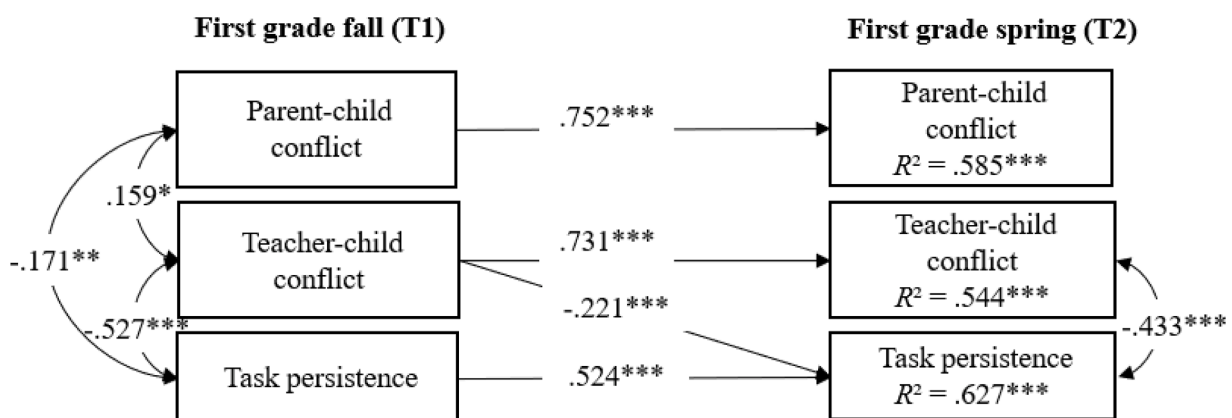

Fig. 3. Associations between parent- and teacher-child conflict and children's task persistence across first grade. Note: Covariates at T1 were allowed to correlate with parent- and teacher-child conflict and task persistence at T1. Covariates at T1 were specified to predict parent- and teacher-child conflict and task persistence at T2. * $p < 0.05$, ** $p < 0.01$, *** $p < 0.001$.

child conflict significantly, thereby rejecting Hypothesis 3b. Notably, all these results were obtained after controlling for autoregressive effects and control variables.

Overall, these findings on parent- and teacher-child conflict revealed that only conflictual teacher-child relationships at the beginning of first grade predicted lower child task persistence at the end of first grade. Children's task persistence did not predict parent- and teacher-child conflict with statistical significance.

3.3. Interaction effect of parent- and teacher-child relationship quality on children's task persistence

To investigate the moderation between parent-child and teacher-child relationship quality, we ran two additional models for closeness and conflict, in which two interaction terms (parent-child closeness \times teacher-child closeness and parent-child conflict \times teacher-child conflict) were added to predict task persistence after controlling for prior task persistence level and control variables (child gender, temperament, performance, and parental education). The model fit for closeness was good ($\chi^2 [2] = 1.477, p = .479, CFI = 1.000, TLI = 1.000, RMSEA = 0.000, SRMR = 0.005$). The interaction effect of parent-child closeness \times teacher-child closeness positively predicted children's task persistence significantly ($\beta = 0.100, p = .020$). The conflict model's fit was also good ($\chi^2 [8] = 122.729, p = .121, CFI = 0.992, TLI = 0.967, RMSEA = 0.041, SRMR = 0.012$), but the interaction term parent-child conflict \times teacher-child conflict did not significantly relate to task persistence ($\beta = -0.023,$

$p = .406$), thereby rejecting Hypotheses 2c and 2d. To investigate the closeness model's interaction effect in greater detail, we calculated and plotted the simple slopes for parent-child closeness at T1 as a predictor of task persistence at T2 for children with a low moderation value (teacher-child closeness: -1 SD) and a high moderator value (teacher-child closeness: +1 SD) (see Fig. 4). The results indicated that when teacher-child closeness at T1 was high, parent-child closeness at T1 positively predicted children's task persistence significantly at the end of first grade (T2) ($\beta = 0.131, p < 0.001$). This suggests that a close relationship with both parents and teachers at the start of first grade was associated with higher children's task persistence at the end of first grade, whereas greater closeness with teachers paired with lower closeness with parents was associated with lower task persistence. However, when children's closeness with their first-grade teachers at T1 was low, parent-child closeness at T1 and task persistence at T2 were not associated at a statistically significant level ($\beta = -0.076, p = .343$). Non-significant slope would indicate that when closeness with the teacher is low, closeness with parents at T1 was not related to children's task persistence at T2 with statistical significance. Despite this, the visual inspection of the non-significant simple slope revealed that when child's closeness with the teacher was low, parent-child closeness was related negatively to their task persistence. This is an interesting result to interpret, suggesting a change of direction in the association between parent-child closeness at T1 and task persistence at T2, depending on low (vs. high) closeness with teachers. Notably, the results presented were obtained even after controlling for child gender,

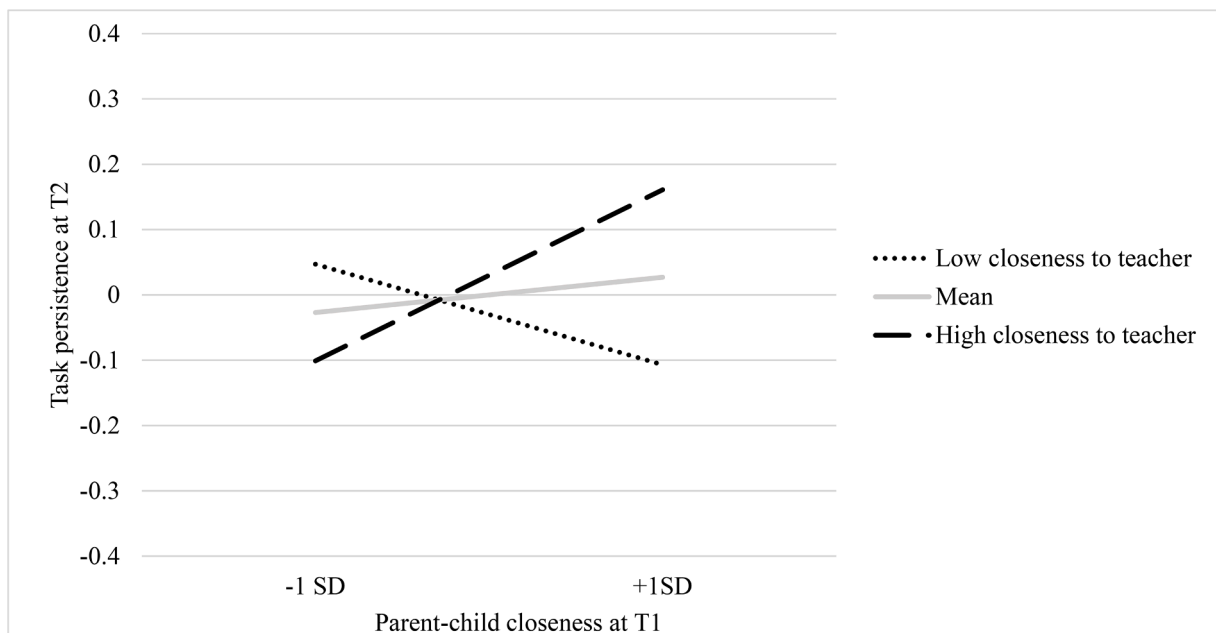

Fig. 4. Teacher–child closeness as a moderator of the associations between parent-child closeness at the beginning of first grade and children’s task persistence at the end of first grade.

Note: T1 = first grade, fall term; T2 = first grade, spring term.

temperament, performance, parental education, and the previous task persistence level at T1. Taken together, the results suggest that strong closeness in both contexts (home and school) at the start of first grade is related to higher children’s task persistence at the end of first grade, thereby rejecting Hypothesis 2a, but supporting Hypothesis 2b.

4. Discussion

The quality of children’s relationships with parents and teachers is recognized as one of the most important sources of social support during the learning process (Heatly & Votruba-Drzal, 2017, 2019; Wentzel, 2016). Thus, the present study on Lithuanians, by simultaneously focusing on parent-child and teacher-child relationships, expanded on the previous literature in several ways. First, the study provides more knowledge about the interplay between parent- and teacher-child relationships and children’s task persistence during one critical development stage—the transition to first grade—as previous studies have paid more attention to younger (Acar et al., 2018; Pianta et al., 1997) or older (Heatly & Votruba-Drzal, 2019) children. Second, the study evaluated associations between relationship quality and a specific motivational-behavioral outcome—task persistence—and provides significant guidelines on what parents and teachers can focus on when helping first-graders remain task-persistent. The results suggest that a conflictual teacher-child relationship at the beginning of first grade is associated negatively with children’s task persistence, over and above the prior task persistence level. Furthermore, the results suggest that children’s task persistence at the beginning of first grade is related positively to subsequent teacher-child closeness after controlling for autoregressive effects and control variables. Third, the study addresses how the interaction effect between parent- and teacher-child relationship quality relates to a child’s task persistence by suggesting that greater closeness in parent-child and teacher-child relationships is positively associated with children’s task persistence at the end of first grade, after adjusting for prior level of task persistence and controls. Finally, the results came from an understudied cultural and education context—Lithuania—providing possibilities for greater generalizability of previous results across countries. Overall, the results provide a broader understanding of how children’s relationships with parents and

teachers interact and offer insights into the reciprocal dynamics of the quality of children’s interpersonal relationships and task persistence after the critical transition to first grade.

4.1. Parent- and teacher-child relationship quality and children’s task persistence

Our first research question investigated the extent to which a child’s closeness and conflict with parents and teachers longitudinally were related to their task persistence at the end of first grade, over and above the prior level of task persistence and control variables. The results partially supported Hypothesis 1b and complemented the existing literature by indicating that a conflictual relationship between the teacher and child were negatively associated with child’s task persistence at the end of first grade. This result aligns well with results from other countries (i.e., the US and Turkey), which found that a conflictual teacher-child relationship is associated negatively with children’s learning outcomes, e.g., behavioral engagement (Heatly & Votruba-Drzal, 2019; Roorda et al., 2017), classroom engagement (Heatly & Votruba-Drzal, 2017), and self-regulation (Acar et al., 2018). Four explanations are possible for this result. First, interaction quality with the teacher can be related to children’s understanding of the learning environment and themselves as learners (Furrer & Skinner, 2003; Wentzel, 2016). Therefore, children may direct less attention and effort to tasks when their relationship with their teacher is conflictual because their need to feel secure and connected is not well met in the classroom (Furrer & Skinner, 2003; Reeve, 2002; Ryan & Deci, 2000). As a result, children may start to think that they are unworthy of acceptance or love and that the classroom environment is not reliable (Alamos & Williford, 2019; Furrer & Skinner, 2003). Similarly, a conflictual relationship with the teacher may relate to negative emotions and lower motivation, in turn also relating to children being less persistent in their academic tasks (Furrer & Skinner, 2003; Merritt et al., 2012; Wentzel, 2016). Second, from the teacher’s perspective, teachers who have conflictual relationships with students might have difficulties sustaining positive classroom organization, which also may be associated with lower task engagement with their students (Cadima et al., 2015). Third, a conflictual teacher-child relationship can be related to negative

teacher emotions (e.g., anger) and other outcomes, e.g., teachers' ineffectiveness at providing appropriate support for a particular child (Spilt & Koomen, 2009). Finally, conflictual teacher-child relationships may be associated with children's disruptive behavior and learning difficulties (Spilt & Koomen, 2009), which may be related to lower task persistence over time.

Contrary to our expectations (Hypothesis 1a), teacher-child closeness was not statistically significantly associated with children's task persistence when both contexts (parents and teachers) were considered simultaneously. This result is consistent with those of previous studies from other countries (e.g., the US; Heatly & Votruba-Drzal, 2017, 2019) and may have a few possible reasons. First, we evaluated how closeness with a teacher measured at the beginning of first grade predicted children's task persistence at the end of first grade. Therefore, the relationship between first-grade teachers and some children may be in the process of being established. As is typical in Lithuania, first-grade students are assigned a new primary school teacher. While the relationship quality between this new teacher and the children was assessed at the beginning of first grade, the teachers might not have made clear judgments about their closeness to the children at the time (Silinskas & Kikas, 2022). However, this result is consistent with studies conducted in other countries (Heatly & Votruba-Drzal, 2017, 2019). Therefore, reasons other than the education system's feature also may explain these results. For example, at the beginning of first grade, children's school readiness (e.g., self-regulation or academic skills) might be a stronger predictor of children's task-persistent behavior than the quality of their relationships with their teachers or parents (Heatly & Votruba-Drzal, 2019). We can assume that children who have more developed self-regulation skills or are more prepared academically for school feel more confident about themselves and, in turn, sustain their positive engagement with difficult tasks more successfully (Skinner, 2016).

Finally, unlike Hypotheses 1a and 1b concerning parent-child relationship quality, neither closeness nor conflict with parents was associated with children's task persistence at the next measurement point. This result aligns well with previous US studies (e.g., Heatly & Votruba-Drzal, 2017, 2019). One possible explanation is that parent-child relationship quality can be less important than teacher-child relationship quality when it comes to day-to-day behavior related to task completion in the classroom (Heatly & Votruba-Drzal, 2017). Task persistence in a classroom represents only a narrow motivational behavioral outcome among children (Reeve, 2002; Skinner, 2016), so we can assume that parent-child relationship quality would exert a greater effect on children's general engagement in school or attitude toward the school (Heatly & Votruba-Drzal, 2019; Pianta, 1997). Second, the teacher assessed task persistence, representing academic persistence related to classroom tasks. Therefore, a child's general task persistence in daily activities at home (e.g., collecting toys after playing, putting together a puzzle, or help with cleaning) may be related more to parent-child relationship quality.

4.2. Interaction effect of parent- and teacher-child relationship quality on children's task persistence

In line with our second research question, the results highlighted the cumulative interaction effect of close relationships with parents and teachers on children's task persistence. These results supported Hypothesis 2b, suggesting that two positive relationship experiences (i.e., a close relationship with parents together with a close relationship with teachers) were associated positively with children's task persistence at the end of first grade, controlling for autoregressive effects and control variables. This result is new and contributes to the growing body of literature indicating that interaction effects between home and school contexts may be associated uniquely with subsequent academic outcomes, e.g., task persistence (Acar et al., 2018; Heatly & Votruba-Drzal, 2017, 2019; Kiuru et al., 2016).

At least three explanations are possible as to why close relationships

with parents and teachers together may be associated longitudinally with a child's task persistence. First, a warm and sensitive relationship with adults is needed for a child to feel a sense of safety and trust (Ryan & Deci, 2000; Rudasill & Rimm-Kaufman, 2009), in which the child knows that they can rely on their parents or teachers' help when facing difficulties. Meanwhile, appropriate support from significant others not only assists in task completion, but also can be related to an adaptive child's learning-related attitude (Davis, 2003; Furrer & Skinner, 2003; Pianta, 1997; Wentzel, 2016) and, thus, task persistence. Second, children who feel connected to and appreciated by significant adults tend to experience the learning process as more interesting and fun, which might be related to higher learning engagement (Furrer & Skinner, 2003). We can assume that parents and teachers who have close relationships with children know them better. Therefore, they may be able to present tasks in a more interesting and engaging way (Deci & Ryan, 2000; Furrer & Skinner, 2003; Pianta, 1997; Wentzel, 2016). Finally, a similar experience in important life domains (e.g., home and school) ensures more balanced needs satisfaction, which has been linked to better well-being and adjustment at school (Milyavskaya et al., 2009). Thus, it is not only children's relationships with significant adults at home or at school that are important for academic outcomes (e.g., task persistence in schoolwork). Instead, close relationships in both contexts are needed for optimal learning outcomes (Bronfenbrenner, 1979).

Furthermore, it might be worthwhile to think about the reasons why parent-child closeness could be related negatively to children's task persistence when closeness to teachers is low (even though the simple slope was non-significant). First, children who have lower closeness to both teachers and parents may persist better with tasks because they are academically well-prepared for school and, in turn, can complete difficult tasks without academic support. Second, children who have closer relationships with parents, but lack closeness with teachers, might be more sensitive or face some difficulties in school, e.g., adaptation or learning. Therefore, they might not persist with classroom tasks effectively. Overall, children with lower closeness to teachers may not feel comfortable participating in classroom activities and, therefore, may not seek help with difficult tasks.

4.3. Longitudinal associations of child's task persistence with the quality of relationships with parents and teachers

Our final research question investigated the longitudinal links between a child's task persistence at T1 and the relationship quality with parents and teachers at T2. This part of the study focused on an area that has received less attention in prior research and, thus, has expanded our knowledge of how a specific motivational characteristic—task persistence—longitudinally relates to parent- and teacher-child relationship quality. The results partially supported Hypothesis 3a and revealed that a child's task persistence at the beginning of first grade can be related positively to the warmer and closer relationship with the teacher at the end of first grade. These results are in line with previous studies reporting that a child's positive academic or behavioral characteristics may be related to more positive instructional and emotional responses on the part of the teacher toward the child (Heatly & Votruba-Drzal, 2017, 2019; Nurmi, 2012; Rudasill & Rimm-Kaufman, 2009; Silinskas et al., 2015). According to previous studies (e.g., Hughes et al., 2008; Nurmi et al., 2018), children's sustained engagement with a task can be linked to a more positive relationship with their teachers, i.e., children's active efforts and willingness to stay on tasks can be associated with teachers' positive feelings (Hughes et al., 2008) and, thus, also may be related to a teacher's positive perception of a child (Rudasill & Rimm-Kaufman, 2009). Consequently, teachers' positive perceptions and emotions, e.g., satisfaction arising from the child's adaptive learning behavior, may be related to teachers' efforts to cultivate a warmer and even more responsive relationship with the child (Heatly & Votruba-Drzal, 2019; Rudasill & Rimm-Kaufman, 2009).

Unlike Hypothesis 3b, we did not find a statistically significant

longitudinal link from children's task persistence to parent- and teacher-child conflict. One possible explanation for these null results could be that negative parent- and teacher-child relationship quality (as a form of conflict) may be linked to more acute and broader behavioral difficulties (e.g., externalizing problems; Heatly & Votruba-Drzal, 2017, 2019; Jaruseviciute et al., 2022), whereas low task persistence during school tasks does not necessarily indicate problematic behavior. Moreover, we can assume that a lower level of task persistence does not necessarily relate to conflicts with teachers, given that at the beginning of first grade, children must learn how to behave in the classroom and direct their attention toward certain tasks. Therefore, the lack of task persistence at the beginning of first grade may not yet be perceived as problematic behavior from the teacher's perspective.

Furthermore, children's task persistence might be not associated longitudinally with parent-child closeness nor parent-child conflict because task persistence was measured as a classroom outcome that is more observable by teachers than parents. Thus, it can be assumed that more general behavior by the child, which also has been seen throughout daily activities at home, would be stronger in relation to parent-child relationship quality (Heatly & Votruba-Drzal, 2019).

4.4. Limitations

The present study has several limitations. First, although our study was longitudinal, no conclusions regarding causal effects between relationship quality and task persistence can be drawn. Only experiments can determine causal effects' direction. The second limitation relates to the cross-lagged panel model (Hamaker et al., 2015). According to Hamaker et al. (2015), the model is not as beneficial in determining predictive associations between variables if the results indicate high stability across variables. Therefore, to validate the present study's results, other statistical techniques need to be applied in future research (e.g., the random intercept cross-lagged panel model, or RI-CLPM). In our study, we unfortunately had only two repeated measurements. Thus, we were unable to construct an RI-CLPM. Third, children's task persistence at the beginning of first grade was related strongly to their task persistence at the end of first grade, indicating that a large amount of variance in task persistence can be explained by the child's task persistence at an earlier measurement point. However, parent- and teacher-child relationship quality notably can be explained as being a uniquely small proportion of the variance in task persistence over and above the level determined at the previous time point. Fourth, although a multi-respondent design is another strength of the study, we used self-report questionnaires that are vulnerable to the social desirability effect (i.e., only parents and teachers reported on their perceptions of relationship quality) and reporter bias (i.e., only teachers reported on relationship quality and task persistence). Thus, future studies need to include children's perceptions of their relationships with parents and teachers. Furthermore, observation data could allow us to broaden our understanding of how parent- and teacher-child relationship quality manifests and is interrelated with children's task persistence. Fifth, the present study focused only on first-grade students. Thus, future studies could provide more information about the development of children's task persistence by following children for longer periods. This is a particularly relevant aspect for future studies given that our preliminary results on mean-level comparisons indicated mean-level changes in relationship quality across time. Sixth, caution should be taken when generalizing our results to different populations, e.g., high, or low socioeconomic status (SES) families and schools or different geographical areas, because our study sample comprised a demographically low-risk Lithuanian population. Therefore, in future research, more attention should be paid to disadvantaged families, as relationship quality in these families may be related differently to children's task persistence. Moreover, for broader generalizations, it would be useful to investigate similar research questions in different countries' cultural and education systems.

4.5. Practical implications

Regarding teachers in the classroom, a few important practical implications can be drawn. First, teachers should avoid forming conflictual relationships with children at the very start of first grade, as these relationships may relate to lower task persistence at the end of first grade. Second, teachers should be aware that they tend to form closer relationships with children who are task persistent in classroom tasks. Thus, interventions that would help manage conflicts with children and strengthen positive relationships could be emphasized and implemented in the classroom.

Based on the present study's results, some other practical recommendations can be made. Professionals working with children starting their school careers should acknowledge and emphasize the importance of parent-teacher collaboration. Positive parent-teacher interaction and collaboration between the home and school need to be emphasized, as a child's closeness with both parents and teachers relates to higher task persistence at the end of first grade.

4.6. Conclusions

Overall, the present study's results provided more insight into longitudinal bidirectional associations between parent- and teacher-child relationships, and a specific child's motivational behavior outcome—task persistence—during the critical academic development stage (first grade) in Lithuania. The results emphasized that parent- and teacher-child relationship quality at the start of first grade can be related to a child's task persistence at the end of first grade. Specifically, the results stressed that a conflictual teacher-child relationship was related negatively to first-grade children's task performance, over and above the prior level of task persistence and control variables. The results also indicated that simultaneous positive relationship experiences at home and at school were related positively to task persistence among children at the end of first grade. Therefore, parents and teachers need to be supportive and establish close relationships with their children. Finally, the results indicated that a child's task persistence level at the beginning of first grade was associated significantly with closer relationships with the teacher at the end of first grade. Consequently, practical interventions may be beneficial, particularly those emphasizing parents and teachers' awareness of how relationship quality with the child may support children's task persistence from the beginning of formal schooling in first grade.

Funding

This study has been financed by the Academy of Finland (#296082, #331525, #336148, and #358041 to Gintautas Silinskas).

CRediT authorship contribution statement

Justina Davolyte: Conceptualization, Methodology, Formal analysis, Writing – original draft, Writing – review & editing, Visualization. **Noona Kiuru:** Conceptualization, Writing – review & editing, Supervision. **Saule Raiziene:** Investigation, Supervision, Project administration. **Gintautas Silinskas:** Conceptualization, Methodology, Writing – review & editing, Supervision, Project administration, Funding acquisition.

Data availability

Data will be made available on request.

References

Acar, I. H., Torquati, J. C., Garcia, A., & Ren, L. (2018). Examining the roles of parent-child and teacher-child relationships on behavior regulation of children at

- risk. *Merrill-Palmer Quarterly*, 64(2), 248–274. <https://doi.org/10.13110/merrpalmquar1982.64.2.0248>
- Ainsworth, M. S. (1989). Attachments beyond infancy. *American Psychologist*, 44(4), 709–716. <https://doi.org/10.1037/0003-066X.44.4.709>
- Alamos, P., & Williford, A. P. (2020). Exploring dyadic teacher–child interactions, emotional security, and task engagement in preschool children displaying externalizing behaviors. *Social Development*, 29(1), 339–355. <https://doi.org/10.1111/sode.12403>
- Aunola, K., & Räsänen, P. (2007). *Test of arithmetic skills. unpublished test material*. Jyväskylän yliopisto: University of Jyväskylä.
- Aunola, K., Nurmi, J.-E., Parrila, R., & Onatsu-Artilommi, T. (2000). *Behavioral strategy rating scale*. Jyväskylä, Finland: University of Jyväskylä.
- Bronfenbrenner, U. (1979). Contexts of child rearing: Problems and prospects. *American Psychologist*, 34(10), 844–850. <https://doi.org/10.1037/0003-066X.34.10.844>
- Bowlby, J. (1982). Attachment and loss: Retrospect and prospect. *American Journal of Orthopsychiatry*, 52(4), 664–678. <https://doi.org/10.1111/j.1939-0025.1982.tb01456.x>
- Bronfenbrenner, U. (1986). Ecology of the family as a context for human development: Research perspectives. *Developmental Psychology*, 22(6), 723–742.
- Buyse, E., Verschueren, K., & Doumen, S. (2011). Preschoolers' attachment to mother and risk for adjustment problems in kindergarten: Can teachers make a difference? *Social Development*, 20(1), 33–50. <https://doi.org/10.1111/j.1467-9507.2009.00555.x>
- Buyse, E., Verschueren, K., Verachert, P., & Damme, J. V. (2009). Predicting school adjustment in early elementary school: Impact of teacher–child relationship quality and relational classroom climate. *The Elementary School Journal*, 110(2), 119–141. <https://doi.org/10.1086/605768>
- Cadima, J., Doumen, S., Verschueren, K., & Buyse, E. (2015). Child engagement in the transition to school: Contributions of self-regulation, teacher–child relationships and classroom climate. *Early Childhood Research Quarterly*, 32(3), 1–12. <https://doi.org/10.1016/j.ecresq.2015.01.008>
- Cohen, J. (1988). *Statistical power analysis for the behavioral sciences* (2nd ed.). Lawrence Erlbaum Associates.
- Davis, H. A. (2003). Conceptualizing the role and influence of student–teacher relationships on children's social and cognitive development. *Educational Psychologist*, 38(4), 207–234. https://doi.org/10.1207/s15326985ep3804_2
- Deci, E. L., & Ryan, R. M. (2000). The “what” and “why” of goal pursuits: Human needs and the self-determination of behavior. *Psychological Inquiry*, 11(4), 227–268. https://doi.org/10.1207/S15327965PLI1104_01
- Driscoll, K., & Pianta, R. C. (2011). Mothers' and fathers' perceptions of conflict and closeness in parent–child relationships during early childhood. *Journal of Early Childhood & Infant Psychology*, (7), 1–24.
- Edwards, C. P., Sheridan, S. M., & Knoche, L. L. (2010). Parent–child relationships in early learning. In E. Baker, P. Peterson, & B. McGaw (Eds.) *International encyclopedia of education* (Vol. 5, pp. 438–443). Elsevier.
- Furrer, C., & Skinner, E. (2003). Sense of relatedness as a factor in children's academic engagement and performance. *Journal of Educational Psychology*, 95, 148–162. <https://doi.org/10.1037/0022-0663.95.1.148>
- Gedutienė, R. (2008). [Doctoral dissertation]. Vilnius University.
- Grimm, K. J., Steele, J. S., Mashburn, A. J., Burchinal, M., & Pianta, R. C. (2010). Early behavioral associations of achievement trajectories. *Developmental Psychology*, 46(5), 976–983. <https://doi.org/10.1037/a0018878>
- Hamaker, E. L., Kuiper, R. M., & Grasman, R. P. P. (2015). A critique of the cross-lagged panel model. *Psychological Methods*, 20(1), 102–116. <https://doi.org/10.1037/a0038889>
- Hamre, B. K., & Pianta, R. C. (2001). Early teacher–child relationships and the trajectory of children's school outcomes through eighth grade. *Child Development*, 72(2), 625–638. <https://doi.org/10.1111/1467-8624.00301>
- Heatly, M. C., & Votruba-Drzal, E. (2017). Parent–and teacher–child relationships and engagement at school entry: Mediating, interactive, and transactional associations across contexts. *Developmental Psychology*, 53(6), 1042–1062. <https://doi.org/10.1037/dev0000310>
- Heatly, M. C., & Votruba-Drzal, E. (2019). Developmental precursors of engagement and motivation in fifth grade: Linkages with parent–and teacher–child relationships. *Journal of Applied Developmental Psychology*, 60, 144–156. <https://doi.org/10.1016/j.appdev.2018.09.003>
- Hu, L. T., & Bentler, P. M. (1999). Cutoff criteria for fit indexes in covariance structure analysis: Conventional criteria versus new alternatives. *Structural Equation Modeling: A Multidisciplinary Journal*, 6(1), 1–55. <https://doi.org/10.1080/10705519909540118>
- Hughes, J. N., Luo, W., Kwok, O. M., & Loyd, L. K. (2008). Teacher–student support, effortful engagement, and achievement: A 3-year longitudinal study. *Journal of Educational Psychology*, 100(1), 1–14. <https://doi.org/10.1037/0022-0663.100.1.1>
- Jaruseviciute, V., Kiuru, N., & Silinskas, G. (2022). Teacher–and parent–child relationships and children's adjustment behaviors in grade 1: The role of temperament. *Journal of Family Psychology*, 36(8), 1363–1375. <https://doi.org/10.1037/fam0001023>
- Kikas, E., & Silinskas, G. (2016). Task persistence mediates the effect of children's literacy skills on mothers' academic help. *Educational Psychology*, 36(5), 975–991. <https://doi.org/10.1080/01443410.2015.1045836>
- Kikas, E., & Tang, X. (2019). Child-perceived teacher emotional support, its relations with teaching practices, and task persistence. *European Journal of Psychology of Education*, 34(2), 359–374.
- Kikas, E., Silinskas, G., Jögi, A. L., & Soodla, P. (2016). Effects of teacher's individualized support on children's reading skills and interest in classrooms with different teaching styles. *Learning and Individual Differences*, 49, 270–277. <https://doi.org/10.1016/j.lindif.2016.05.015>
- Kiuru, N., Laursen, B., Aunola, K., Zhang, X., Lerkkanen, M. K., Leskinen, E., & Nurmi, J. E. (2016). Positive teacher affect and maternal support facilitate adjustment after the transition to first grade. *Merrill-Palmer Quarterly*, 62(2), 158–178. <https://doi.org/10.13110/merrpalmquar1982.62.2.0158>
- Kiuru, N., Wang, M.-T., Salmela-Aro, K., Kannas, L., Ahonen, T., & Hirvonen, R. (2020). Transactional associations between adolescents' interpersonal relationships, school well-being, and academic achievement during educational transitions. *Journal of Youth and Adolescence*, 49, 1057–1072. <https://doi.org/10.1007/s10964-019-01184-y>
- Koepke, M. F., & Harkins, D. A. (2008). Conflict in the classroom: Gender differences in the teacher–child relationship. *Early Education and Development*, 19(6), 843–864. <https://doi.org/10.1080/10409280802516108>
- Lerkkanen, M.-K., Poikkeus, A.-M., & Ketonen, R. (2006). *ARMI—Lukija kirjoitustaidon arviointimateriaali 1. luokalle [ARMI—A tool for assessing reading and writing skills in first grade]*. WSOY.
- LR Ministry of Education and Science (2022). *Curriculum of Pre-Primary Education [Priešmokyklinio Ugdymo Bendroji Programa]*. Available online at: Priešmokyklinio ugdymo programa - Švietimo, mokslo ir sporto ministerija (Irv.lt) (accessed May 2, 2024).
- Maldonado-Carreño, C., & Votruba-Drzal, E. (2011). Teacher–child relationships and the development of academic and behavioral skills during elementary school: A within- and between-child analysis. *Child Development*, 82(2), 601–616. <https://doi.org/10.1111/j.1467-8624.2010.01533.x>
- Merritt, E. G., Wanless, S. B., Rimm-Kaufman, S. E., Cameron, C., & Peugh, J. L. (2012). The contribution of teachers' emotional support to children's social behaviors and self-regulatory skills in first grade. *School Psychology Review*, 41(2), 141–159. <https://doi.org/10.1080/02796015.2012.12087517>
- Milyavskaya, M., Gingras, I., Mageau, G. A., Koestner, R., Gagnon, H., Fang, J., & Boiché, J. (2009). Balance across contexts: Importance of balanced need satisfaction across various life domains. *Personality and Social Psychology Bulletin*, 35(8), 1031–1045. <https://doi.org/10.1177/0146167209337036>
- Murray, C. (2009). Parent and teacher relationships as predictors of school engagement and functioning among low-income urban youth. *The Journal of Early Adolescence*, 29(3), 376–404. <https://doi.org/10.1177/0272431608322940>
- Muthén, L. K., & Muthén, B. O. (2017). *Mplus user's guide* (8th ed.).
- Nurmi, J. E., & Kiuru, N. (2015). Students' evocative impact on teacher instruction and teacher–child relationships: Theoretical background and an overview of previous research. *International Journal of Behavioral Development*, 39(5), 445–457. <https://doi.org/10.1177/0165025415592514>
- Nurmi, J. E., Silinskas, G., Kiuru, N., Pakarinen, E., Turunen, T., Siekkinen, M., ... Lerkkanen, M. K. (2018). A child's psychological adjustment impacts teachers' instructional support and affective response. *European Journal of Psychology of Education*, 33, 629–648.
- Nurmi, J. E. (2012). Students' characteristics and teacher–child relationships in instruction: A meta-analysis. *Educational Research Review*, 7(3), 177–197. <https://doi.org/10.1016/j.edurev.2012.03.001>
- Onatsu-Artilommi, T., & Nurmi, J. E. (2000). The role of task-avoidant and task-focused behaviors in the development of reading and mathematical skills during the first school year: A cross-lagged longitudinal study. *Journal of Educational Psychology*, 92(3), 478–491. <https://doi.org/10.1037/0022-0663.92.3.478>
- Pianta, R. C., & Stuhlman, M. W. (2004). Teacher–child relationships and children's success in the first years of school. *School Psychology Review*, 33(3), 444–458. <https://doi.org/10.1080/02796015.2004.12086261>
- Pianta, R. C. (1992). *Student–teacher relationship scale—Short form*. The University of Virginia.
- Pianta, R. C. (1997). Adult–child relationship processes and early schooling. *Early Education and Development*, 8(1), 11–26. https://doi.org/10.1207/s15566935eed0801_2
- Pianta, R. C. (2001). *Student–teacher relationship scale—Short form*. Psychological Assessment Resources, Inc.
- Putnam, S. P., & Rothbart, M. K. (2006). Development of short and very short forms of the children's behavior questionnaire. *Journal of Personality Assessment*, 87(1), 102–112. https://doi.org/10.1207/s15327752jpa8701_09
- Reeve, J. (2002). Self-determination theory's application to educational settings. In E. L. Deci, & R. M. Ryan (Eds.), *Handbook of self-determination research* (pp. 183–203). The University of Rochester Press.
- Roorda, D. L., Jak, S., Zee, M., Oort, F. J., & Koomen, H. M. (2017). Affective teacher–student relationships and students' engagement and achievement: A meta-analytic update and test of the mediating role of engagement. *School Psychology Review*, 46(3), 239–261.
- Rothbart, M. K., Ahadi, S. A., Hershey, K. L., & Fisher, P. (2001). Investigations of temperament at three to seven years: The children's behavior questionnaire. *Child Development*, 72(5), 1394–1408. <https://doi.org/10.1111/1467-8624.00355>
- Rudasill, K. M., & Rimm-Kaufman, S. E. (2009). Teacher–child relationship quality: The roles of child temperament and teacher–child interactions. *Early Childhood Research Quarterly*, 24(2), 107–120. <https://doi.org/10.1016/j.ecresq.2008.12.003>
- Ryan, R. M., & Deci, E. L. (2000). The darker and brighter sides of human existence: Basic psychological needs as a unifying concept. *Psychological Inquiry*, 11(4), 319–338. https://doi.org/10.1207/S15327965PLI1104_03
- Sameroff, A. J., & Mackenzie, M. J. (2003). Research strategies for capturing transactional models of development: The limits of the possible. *Development and Psychopathology*, 15(3), 613–640. <https://doi.org/10.1017/S0954579403000312>

- Settanni, M., Longobardi, C., Sclavo, E., Fraire, M., & Prino, L. E. (2015). Development and psychometric analysis of the student–teacher relationship scale–short form. *Frontiers in Psychology*, *6*, 1–7. <https://doi.org/10.3389/fpsyg.2015.00898>
- Silinskas, G., & Kikas, E. (2022). Patterns of children’s relationships with parents and teachers in grade 1: Links to task persistence and performance. *Frontiers in Psychology*, *13*, 1–18. <https://doi.org/10.3389/fpsyg.2022.836472>
- Silinskas, G., Dietrich, J., Pakarinen, E., Kiuru, N., Aunola, K., Lerkkanen, M. K., & Nurmi, J. E. (2015). Children evoke similar affective and instructional responses from their teachers and mothers. *International Journal of Behavioral Development*, *39* (5), 432–444. <https://doi.org/10.1177/0165025415593648>
- Skinner, E. A. (2016). Engagement and disaffection as central to processes of motivational resilience and development. In K. R. Wentzel, & D. B. Miele (Eds.), *Handbook of motivation at school* (2nd ed., pp. 145–168). Routledge.
- Spilt, J. L., & Koomen, H. M. (2009). Widening the view on teacher–child relationships: Teachers’ narratives concerning disruptive versus nondisruptive children. *School Psychology Review*, *38*(1), 86–101. <https://doi.org/10.1080/02796015.2009.12087851>
- Torgimson, S. J., Tan, P. Z., & Grammer, J. K. (2021). Associations among response inhibition, motivational beliefs, and task persistence in early elementary school. *Journal of Experimental Child Psychology*, *208*, 1–16. <https://doi.org/10.1016/j.jecp.2021.105141>
- Verschueren, K., & Koomen, H. M. (2012). Teacher–child relationships from an attachment perspective. *Attachment & Human Development*, *14*(3), 205–211. <https://doi.org/10.1080/14616734.2012.672260>
- Verschueren, K. (2015). Middle childhood teacher–child relationships: Insights from an attachment perspective and remaining challenges. *New Directions for Child and Adolescent Development (Special Issue: Attachment in Middle Childhood: Theoretical Advances and New Directions in an Emerging Field)*, *148*, 77–91.
- Viljaranta, J., Silinskas, G., Lerkkanen, M. K., Hirvonen, R., Pakarinen, E., Poikkeus, A. M., & Nurmi, J. E. (2018). Maternal homework assistance and children’s task-persistent behavior in elementary school. *Learning and Instruction*, *56*, 54–63. <https://doi.org/10.1016/j.learninstruc.2018.04.005>
- Wentzel, K. R. (2016). Teacher–student relationships. In K. R. Wentzel, & D. B. Miele (Eds.), *Handbook of motivation at school* (2nd ed., pp. 211–225). Routledge.
- Wu, J. Y., Hughes, J. N., & Kwok, O. M. (2010). Teacher–student relationship quality type in elementary grades: Effects on trajectories for achievement and engagement. *Journal of School Psychology*, *48*(5), 357–387. <https://doi.org/10.1016/j.jsp.2010.06.004>
- Zhang, X., Nurmi, J. E., Kiuru, N., Lerkkanen, M. K., & Aunola, K. (2011). A teacher-report measure of children’s task-avoidant behavior: A validation study of the behavioral strategy rating scale. *Learning and Individual Differences*, *21*(6), 690–698. <https://doi.org/10.1016/j.lindif.2011.09.007>